

Figure 1 Variable-speed electronic controller

# SOLVING OVERPRESSURE PROBLEMS WITH A VARIABLE-SPEED FIRE PUMP

by William F. Stelter, PE, and James Peterkin, PE

The selection of a fire pump for a specific design flow and pressure should be relatively easy if you have an accurate test curve for the available water supply; however, often-times overpressures occur at no flow due to inaccurate or nonexistent water tests, as well as wide suction pressure swings between static and residual conditions and higher shutoff pressures on fire pumps. These problems now can be solved by controlling the discharge pressure of a fire pump with a variable-speed electric controller or a pressure-limiting diesel driver (see Figures 1 and 2).

### SOME HISTORY

In the past, main relief valves were used in an attempt to control overpressure conditions. The results were poor at best since they would open during the weekly testing required by NFPA 25: *Standard for the Inspection, Testing, and Maintenance of Water-Based Fire Protection Systems*. During the testing, the rated flow of the fire pump was typically dumped outside the building, and besides wasting approximately 1,000 gallons per minute for 10 minutes, or 10,000 gallons a week, this also presented a hazard to anyone walking by or working around the external discharge pipe when the pump was turned on.

Then, in the 2003 edition of NFPA 20: *Standard for the Installation of Stationary Pumps for Fire Protection* the use of main relief valves to control the discharge pressure of the fire pump was prohibited with the addition of paragraph 5.7.4.2 (now 4.7.7.2 in the 2010 edition). At the same time, the

standard allowed the use of variable-speed pressure-limiting control with the addition of paragraph 5.7.4.3 (now 4.7.7.3 in the 2010 edition) as a better means to control overpressures.

The first Underwriters Laboratories (UL)-listed variable-speed electric fire pump controller was introduced by Master Control Systems in 2003 and was shipped by the end of that year. In 2004, Clarke Fire Protection Products introduced the first pressure-limiting device (PLD) diesel engine.

NFPA 20 further expanded on the requirements for variable-speed electric fire pump controllers in the 2007 edition by adding a new section (10.10). In 2008, Factory Mutual adopted these latest changes and approved its first variable-speed electric fire pump controller. Since then, many fire pumps have been successfully provided with variable-speed electric controllers or pressure-limiting diesel drivers.

### LET'S LOOK AT THE BASIC ENGINEERING

For centrifugal pumps, the pressure changes by the square of the speed. Thus, using a pump that is rated for 132 pounds per square inch (psi) at rated flow and 148 psi at no-flow pressure, the pressures will be lowered to  $0.9 \times 0.9 = 0.81$  times the full speed values, if the speed is reduced by 10 percent. This reduces the pressure at rated flow from 132 psi to 107 psi and the pressure at no-flow from 148 psi to 120 psi. See Figure 3 for further examples of how the pressure varies at different speeds.

For electric motors, a variable-frequency drive (VFD) is used in the electric fire pump controller to change the speed

Figure 2 Pressure-limiting diesel driver



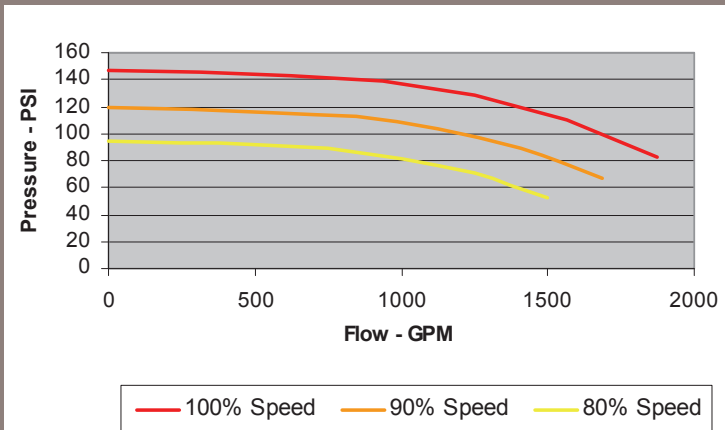

Figure 3 Fire pump curve at various speeds

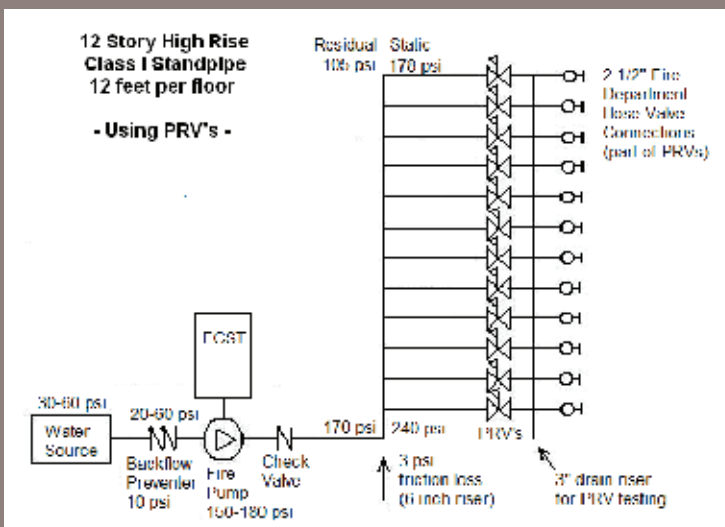

Figure 4 Traditional riser diagram

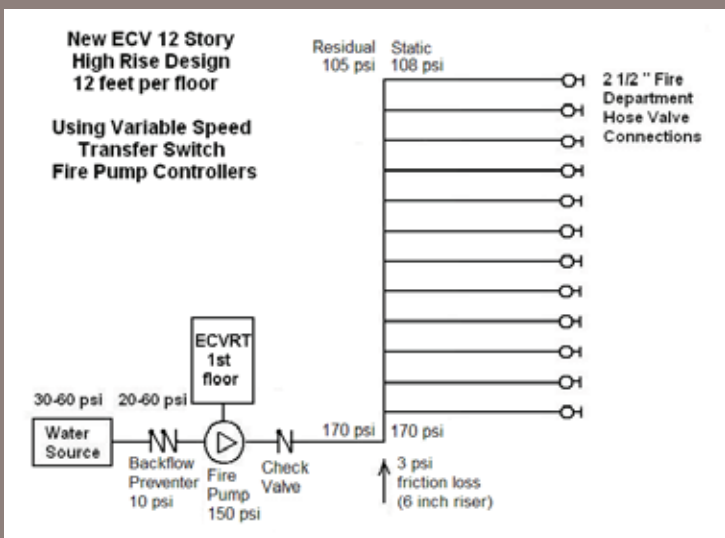

Figure 5 Riser diagram with variable-speed fire pump

of the motor. The VFD converts the incoming AC power at 60 hertz (50 Hz outside the United States) to DC power and then recreates AC power at its load terminals to run the motor at the appropriate frequency commanded by the internal control loop. Since the speed of the motor is directly proportional to the frequency supplied to it, operating the motor at 54 Hz instead of 60 Hz will run the motor at 1,620 revolutions per minute (rpm) instead of 1,800 rpm.

By adjusting the speed as the flow changes, the discharge pressure of the fire pump can be held constant for any flow. This is done with a control loop that monitors the discharge pressure and compares it to the set point or set pressure saved in the VFD. This can be done easily in the field. If the pressure is too high, the control loop slows the speed of the motor. If the pressure is too low, it speeds up the motor. Of course, as is the case with any closed-loop system, care must be taken to ensure that the system is stable under all flow conditions, not just a few points.

For diesel engines, a pressure-limiting device is added as an accessory package to reduce the engine speed only when the discharge pressure of the fire pump is greater than the factory set point of the PLD. At this point, the engine throttle is adjusted to reduce the speed, and thereby the pressure, to the set point.

### FOR EXAMPLE

A standard three-phase induction motor runs at a constant speed based on the line frequency and the number of poles in the motor. Thus, for a 4-pole motor at 60 Hz, the motor's synchronous speed is 1,800 rpm. This will change slightly based on the slip frequency when loaded, which is about 50 rpm, so the loaded speed is about 1,750 rpm. When this speed is applied to a pump, the discharge pressure will vary based on its pump curve and the input suction pressure.

For example, if a 150-psi rated fire pump with a 20 percent rise to shutoff is connected to a city water supply with a residual pressure of 30 psi and a 10-psi drop through the backflow preventer, the discharge pressure of the fire pump will be 170 psi at design. If the city water pressure rises to 60 psi at no flow, the discharge pressure of the fire pump will be 240 psi. This is based on the 30-psi increase in suction pressure, the 20 percent rise to shutoff of the pump, and no pressure loss across the backflow preventer. Traditionally, any pressure more than 175 psi in the standpipe is handled by using pressure-reducing valves (PRVs). See Figure 4 for a traditional riser diagram with PRVs.

With variable-speed technology, an alternate solution is available to solve this overpressure problem. The variable-speed electric controller or pressure-limiting diesel driver varies the speed of the driver using a built-in control loop to maintain a constant discharge pressure at the pump, regardless of the changes in suction pressure or rise to shutoff of the fire pump. Figure 5 shows the same riser diagram with a variable-speed fire pump. Note the elimination of the PRVs.

## HOW IS VARIABLE SPEED FOR FIRE PUMPS DIFFERENT THAN FOR ANY OTHER PUMPS?

Of course, VFDs for electric motors and throttle control on diesel engines have been used in other industries for decades, but they have been allowed for fire pumps only recently. The advantage for the fire protection community is that these devices have been previously field proven and are now extremely reliable.

Even so, in the rare event that the pressure-limiting device fails, NFPA 20 requires an automatic bypass for the VFD in a variable-speed electric controller and a return to full speed through a governor control on a PLD diesel engine. In either case, the fire pump will run at full speed, so to prevent an overpressure in the system, NFPA 20 Section 4.18.1 requires a main relief valve to be added into the system for this purpose. Now the relief valve is used as intended by its listing agency, which is to relieve an unintended overpressure, and is not to be used as part of the fire protection design. It should be set to operate approximately 10 psi above the set pressure of the VFD or PLD so it operates only when the pump is in full-speed mode.

In addition, NFPA 20 requires third-party listing for these devices. Both UL and FM have listed and approved VFDs with electric motors and throttle-control PLDs on diesel engines for fire pump applications.

## THINGS TO CONSIDER WHEN USING A VFD OR PLD

- Use a UL/FM-listed and approved variable-speed electric fire pump controller in accordance with NFPA 20 Section 10.10 or a pressure-limiting diesel driver in accordance with NFPA 20 Section 11.2.4.3.
- Be sure to use a UL-listed motor suitable for inverter duty and marked accordingly per NFPA 20 Paragraph 9.5.1.4.
- Do not use the motor service factor with VFD fire pumps per NFPA 20 Paragraph 9.5.2.2(2).
- Be sure to add a main relief valve to the system. NFPA 20 Section 4.18.1 requires the use of a main relief valve if the bypass pressure is higher than the system's rated pressure.

## APPLICATIONS

### Eliminate PRVs in Low- to Mid-rise Buildings

Many buildings that are 150 feet in elevation from the discharge of the fire pump to the top-most outlet (see Figure 6) can benefit from variable speed by the possibility of eliminating all of the PRVs that would have been used in a traditional system. This also eliminates the drain risers, annual PRV checks, and full-flow PRV tests every five years.

The reason 150 feet is such a good elevation for the VFD is that you can set the pressure at the discharge of the pump

# MASTER

## Variable Speed Fire Pump Controllers

- **Inventors of Variable Speed for Fire Pumps**
- **First to Obtain UL Listing and FM Approval**
- **5 Year Warranty**
- **Lightning Guarantee**
- **PhaseSmart Technology**

No Flow to Full Flow, the Pressure's the Same



Master Control Systems, Inc. • [www.mastercontrols.com](http://www.mastercontrols.com) • 847-295-1010



Figure 6 Using variable speed on a low-rise building can potentially eliminate the need for pressure-reducing valves.

Figure 8 Using variable speed in a high-rise can help reduce zones and eliminate a storage tank at the top of the building.



at 175 psi, drop 65 psi due to elevation, and have 110 psi at the top-most outlet. This leaves 10 psi for friction loss, which typically can be achieved with straight runs of 4- and 6-inch riser pipe.

### Enable Dual Water Supplies in High-rise Buildings in Seismic Areas

High-rise structures in certain seismic categories may be required by the building code to have two independent water sources. The primary source is typically the city water supply, and the secondary source can be a ground-level or buried water tank (see Figure 7), which creates a large suction pressure variation at the inlet of the fire pump.

For instance, consider a hospital located in a city with a static suction pressure of 50 psi. The pump must be sized to boost the pressure from the storage tank to the top of the building since the city water supply might not be available during a seismic event. This creates a large overpressure problem under normal city water pressure conditions. If the fire pump were rated for 165 psi with a 20 percent rise to shutoff, the no-flow fire pump discharge pressure would be approximately 248 psi. Using a variable-speed electric fire pump controller with a VFD, the set pressure can be adjusted to hold 165 psi regardless of changes in the suction pressure. When transitioning from one suction supply to the other, the VFD control loop quickly adjusts the discharge pressure of the fire pump back to the set pressure with no pump cavitation occurring.

### Eliminate Tank on Top of High-rise Building

A 64-story high-rise building in Chicago (see Figure 8) uses variable speed not to eliminate PRVs, but to eliminate the

fourth zone and storage tank at the top of the building. (It didn't eliminate PRVs because the City of Chicago does not allow their use as a general rule.) The City of Chicago allows 65 psi at the highest outlet, so the building was split into three zones based on the ability of the VFD to closely control the pressure in each zone. By using variable-speed transfer switch controllers, the pressure from no flow to full flow in each zone was controlled to within a few psi.

### Airport Foam Systems

Foam systems are very unique since they are never at partial flow. It's all or nothing. When the system operates, the pump runs far out on its curve until the pipes fill up and create the designed friction loss. Once they do, the discharge pressure rises to its rated value, so you wouldn't think you would need a variable-speed fire pump. However, when it's being tested at no flow, it's doing nothing, so the static pressure combined with the no-flow rise to shutoff pressure of the pump often exceeds 175 psi. Instead of using large paralleled PRVs, the VFD easily controls the pressure at its design pressure at full flow when the system is operated and at no flow when the system is tested (see Figure 9).

### Complex Fire Protection Systems

Fire protection systems for large institutions such as a college or hospital (see Figure 10) are often quite complex, with sprinkler systems, standpipe systems, dry pipe systems, and water mist systems all in the same building. Traditionally, PRVs were used to control overpressures in these systems, but today variable speed works quite well with all of these systems and eliminates the PRVs, drain risers, and NFPA 25 PRV testing.



Figure 7 When buried storage tanks are required, using variable speed can quickly adjust the discharge pressure of the fire pump without cavitation.

To ensure that the VFD works correctly in all of these systems, the fire pump must be checked at every possible flow condition to verify system stability.

## CONCLUSION

Variable-speed fire pumps, controlled by either variable-speed electric fire pump controllers or pressure-limiting diesel engine drivers, are now UL/FM approved, used in virtually all types of fire pump systems, and have been field proven. They are available from many manufacturers and are routinely being used to solve overpressure problems in fire sprinkler systems. **PSD**



**William Stelter, PE**, is President of Master Control Systems Inc. and inventor of the first variable-speed fire pump controller. He is a Professional Engineer licensed in Illinois, an NFPA 20 Committee Member representing NEMA, and chair of the NFPA Variable-Speed Task Force.



**James Peterkin, PE**, is a Senior Fire Protection Engineer with Heery International and has 10 years of experience with Factory Mutual. He is a member of the NFPA 1 Committee and the NFPA 14 Committee. For more information or to comment on this article, e-mail [articles@psdmagazine.org](mailto:articles@psdmagazine.org).



Figure 9 A variable-speed fire pump easily controls the design pressure at full flow when a foam system is operated and at no flow when the system is tested.

Want to learn more about fire pump design and testing? Register now for the 2011 ASPE Technical Symposium at [aspe.org/2011TechnicalSymposium](http://aspe.org/2011TechnicalSymposium).



Figure 10 A variable-speed fire pump can help simplify complex fire protection systems for large institutions.